

# GREYSTONE ENERGY SYSTEMS INC

## ROOM PRESSURE MONITOR RPC Series



### Precision room pressure control/sensing

#### FEATURES:

- Low pressure monitoring to -0.125"WC ( 30Pa)
- 4 selectable ranges per model
- Precision silicon sensor
- Selectable analog outputs
- Optional BACnet Communications
- Alarm functions with selectable trip point
- Easy set up via menu on LCD display

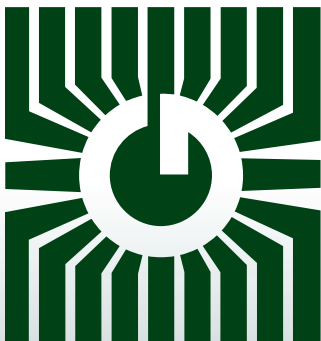

*Peace of mind  
through reliable  
pressure monitoring*

**DESCRIPTION:**

The RPC Series room pressure monitor/transmitter is used to measure differential pressure in the range of 0.125 to 1"WC or 30 to 250 Pa and provide either an analog or BACnet compatible signal to a building automation system.

It combines precision high sensitivity silicon sensing capabilities and the latest ASIC technology to substantially reduce offset errors due to changes in temperature, stability to warm up, long term instability and position sensitivity.

It features an LCD to display the pressure value, several bi-directional pressure ranges and field-selectable output signal types for the most flexible application. The device has an on-board auto-zero function. It features an alarm output with a adjustable trip points for high and low alarm levels, an on-board buzzer, a remote buzzer output with silence switch and a flashing alarm LED.

**SPECIFICATIONS:**

Pressure Ranges .....	± 1" WC, ± 0.5" WC, ± 0.25" WC, ± 0.125" WC ± 250 Pa, ± 125 Pa, ± 60 Pa, ± 30 Pa
Accuracy .....	± 1% F.S.O. (±2% F.S.O. for 0.125"WC and 30 Pa ranges)
Stability .....	± 1% FS max (1 year)
Thermal Effects .....	< ± 3.5% FS max, 5 - 50°C (41 - 122°F)
Response Time .....	0 - 60 Sec (menu selectable)
Proof Pressure .....	100" WC (24.9 kPa)
Burst Pressure .....	200" WC (49.8 kPa)
Operating Conditions .....	0 - 60°C (32 - 140°F), 10 - 90% RH non-condensing
Storage Temperature .....	-40 - 70°C (-40 - 158°F)
Media Compatibility .....	Dry air and inert gas
Zero Adjustment .....	Pushbutton auto-zero
Power Supply .....	24 Vac/dc, ±10%
Power Consumption .....	70 mA max with alarms on (80 mA with BACnet option)
Output Signal .....	4-20 mA (3-wire), 0-5 Vdc or 0-10 Vdc (3-wire), field selectable
Output Drive .....	750 Ω max (4-20 mA), 2KΩ min (voltage)
Input Voltage Effect .....	Negligible over specified operating range
Protection Circuitry .....	Reverse voltage protected and output limited
Wiring Connections .....	Screw terminal block (14 to 22 AWG)
Pressure Connections .....	Ports for 1/16" ID tubing (1/8" ID Adapters included)
Enclosure .....	Wall mount, White ABS, IP30 (NEMA1)
Dimensions .....	84 W x 119 H x 29 D mm (3.3" x 4.7" x 1.15")
Weight .....	115 grams (4 oz)

**LCD DISPLAY**

Display Size .....	38.1 x 16.5 mm (1.5" x 0.65")
Digit Height .....	11.43 mm (0.45")
Symbols .....	" WC, Pa
Backlight .....	Enable/disable via menu

**ALARM FUNCTIONS**

Alarm Relay Output .....	N.O. contact, 2 Amps @ 120 Vac or 30 Vdc
Alarm Relay Trip Point .....	Upper and lower trip levels adjustable over the pressure range
Alarm Relay Delay .....	0 to 10 Minutes (menu selectable)
Alarm Visual Indication .....	Red flashing LED
Alarm Audible Indication .....	On-board buzzer, 85 db on high range (menu selectable)
Remote Buzzer Output .....	Output to control remote audible alarm. (Part Number AA-1)

**OPTIONAL BACnet COMMUNICATIONS**

Communications .....	2-wire RS-485, BACnet MS/TP protocol
Baud Rate .....	Locally set to 9600, 19200, 38400 or 76800
MAC Address Range .....	Locally set to 0-127 (factory default is 3)

**BACnet® COMMUNICATION**



BACnet® is a data communication protocol for building automation and control networks. The detector communicates on a standard 2-wire RS-485 MS/TP (master-slave/token-passing) network designed to run at speeds from 9600 to 76800 baud over twisted pair wiring.

BACnet is a registered trademark of ASHRAE. ASHRAE does not endorse, approve or test products for compliance with ASHRAE standards. Compliance of listed products to the requirements of ASHRAE Standard 135 is the responsibility of BACnet International (BI). BTL is a registered trademark of BI.

**PRODUCT ORDERING INFORMATION:**

MODEL	Product Description		
RPC	Room Pressure Monitor/Transmitter		
CODE	Range		
1	±1 "WC, ±0.5 "WC, ± 250 Pa, ± 125 Pa		
2	±0.25 "WC, ± 0.125 "WC, ± 60 Pa, ± 30 Pa		
CODE	Communications		
-	None (Leave blank)		
BAC	BACnet Communications		
CODE	Options		
AC	Continental pick-up port		
SP	Stainless plate pick-up port		
OP	Outside pick-up port		
RPC	1	BAC	AC

Greystone Energy Systems, Inc. reserves the right to make design modifications without prior notice.

**PCB/WIRING INFORMATION**

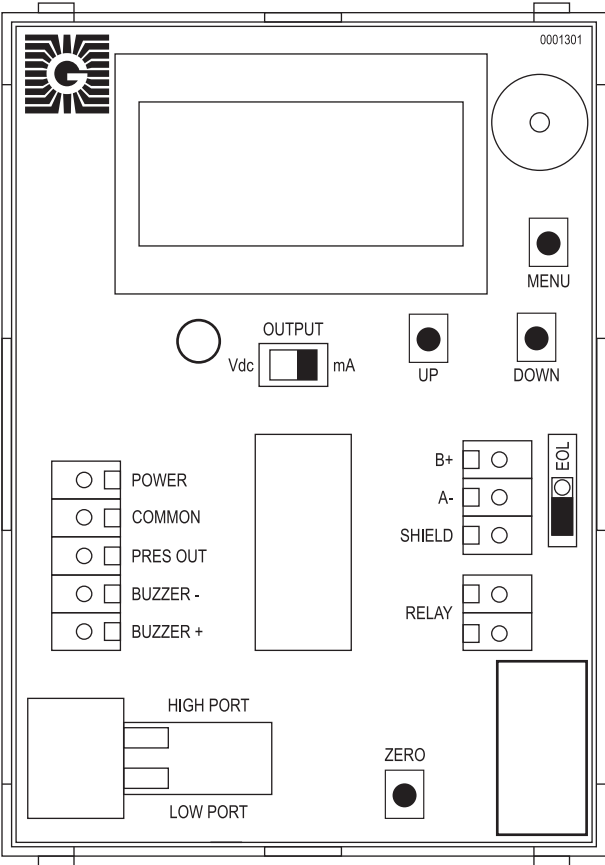

Terminal	Function
POWER	From +24 Vac/dc of controller or power supply
COMMON	To GND or COMMON of controller
PRES OUT	To analog input of controller 4-20 mA or 0-5 Vdc or 0-10 Vdc
BUZZER -	To GND or COMMON of controller
BUZZER +	+24 Vac/dc to remote buzzer (Part # AA-1)
B +	To + of communications bus
A -	To - of communications bus
SHIELD	To communications bus shield
RELAY	To digital input of controller

\* Some models do not have all these features

**DIMENSIONS:**

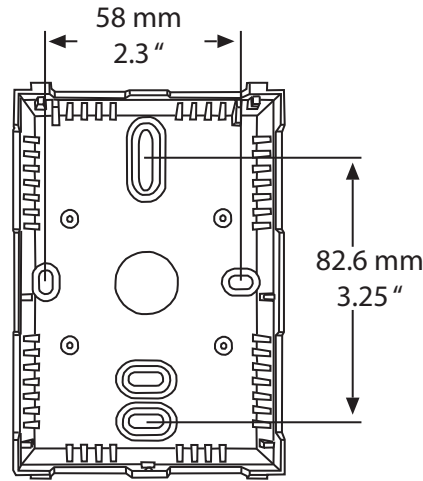
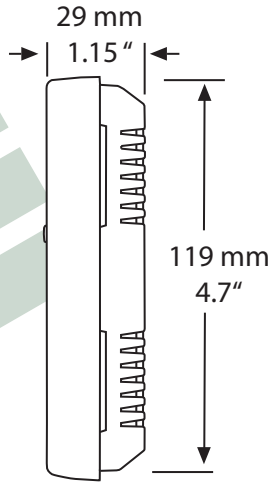
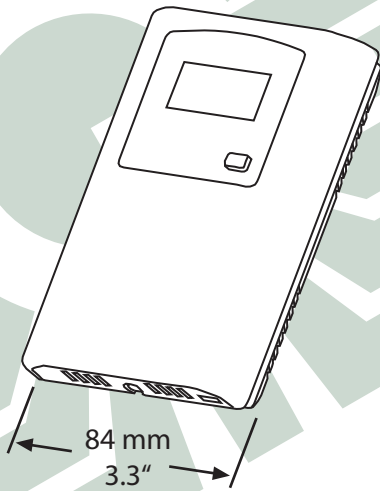

**ACCESSORIES:**



Continental (AC)  
Pick-up Port  
(AC Option)



Outside  
Pick-up Port  
(OP Option)

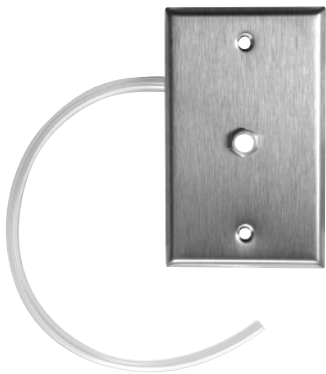

Stainless Plate  
Pick-up Port  
(SP Option)



Remote Audible Alarm  
Part # AA-1  
(to be ordered  
separately)



**GREYSTONE**  
ENERGY SYSTEMS INC

Greystone Energy Systems, Inc.  
150 English Drive, Moncton,  
New Brunswick, Canada E1E 4G7  
(506) 853-3057 Fax: (506) 853-6014  
North America: 1-800-561-5611  
e-mail: mail@greystoneenergy.com  
www.greystoneenergy.com

**RoHS**  
COMPLIANT



*Greystone Energy Systems Inc. is one of North America's largest ISO registered manufacturers of HVAC/R sensors and transmitters for Building Automation Management Systems.*

*We have conscientiously established a worldwide reputation as an industry leader by maintaining leading-edge design technology, prompt technical support, and a commitment to on-time deliveries. We take pride in our Quality Management System which is ISO 9001 certified, assuring our customers of consistent product reliability.*

GREYSTONE HAS AN **ISO 9001** REGISTERED QUALITY SYSTEM